

KnightStar 330 component descriptions

Item	Description
1	Base, enclosure
2	Foot, base, enclosure
3	Label, KS 330
4	Label, serial number
5	Case, foam
6	Suspension/muffler, blower
7	Blower assembly
8	Ferrite, clamp on
9	Dampener
10	Wire patch, dampener
11	Chassis, enclosure
12	Screen, blower housing
13	Bellows, blower housing
14	Tube, pitot
15	Screw, Torx, hilo 2.2 (4pl)
16	Baffle
17	Filter, air inlet
18	Adhesive foam, fan base
19	Assembly, cooling fan
20	Assembly, PCB alarm board
21	Tube, silicone, 10.0"
22	Tube, silicone, 4.25"
23	Tube, silicone, 1.25"
24	Spacer (2 pl)
25	Insulator, LCD
26	LCD display, 16x24
27	Cover, Enclosure
28	Switch, Membrane
29	Pad, foam, cover, interior
30	Screw, 4-20 x .375, PH. pan head (2 pl)
31	RS-232 PCBA
32	Insulator, RS-232 PCBA

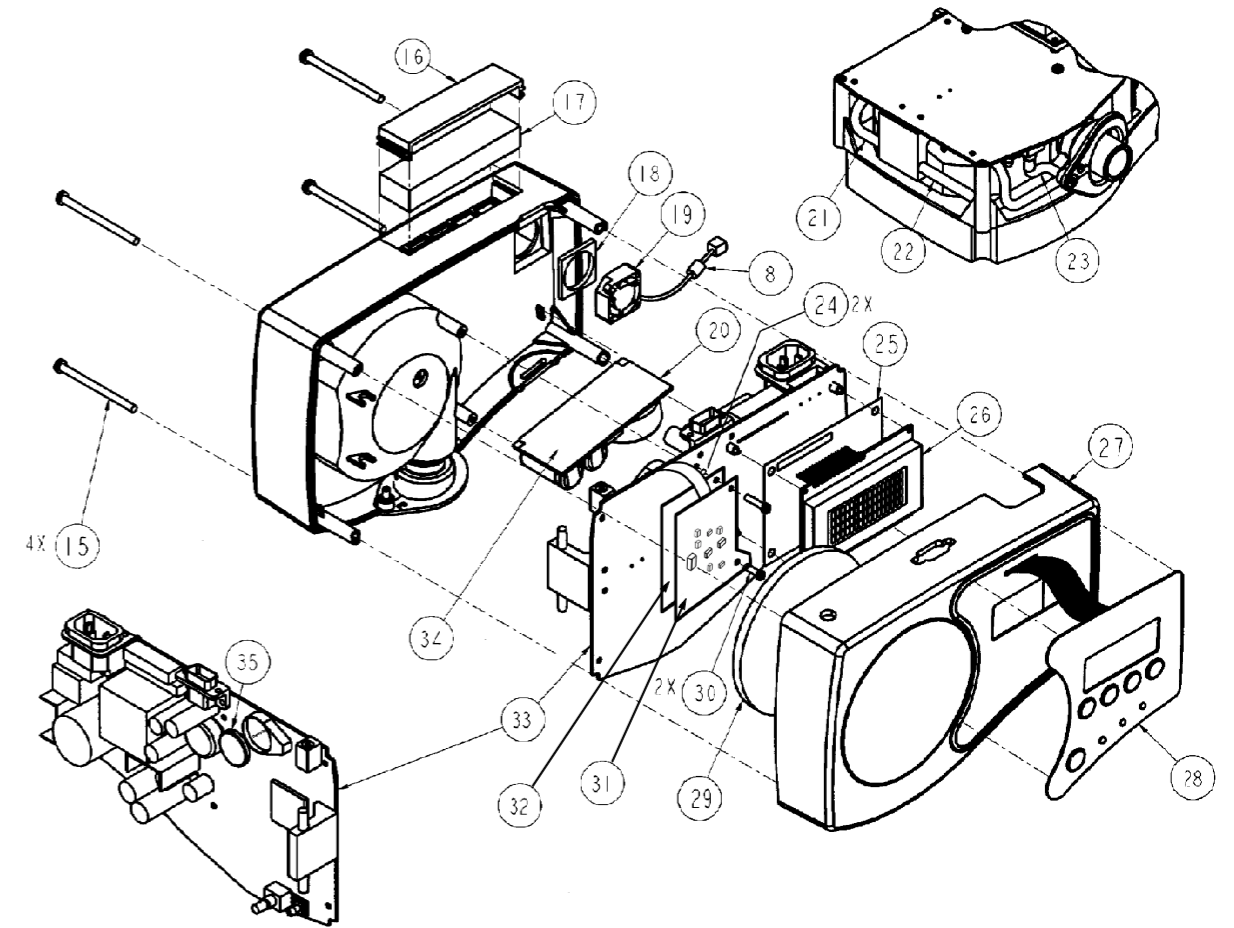
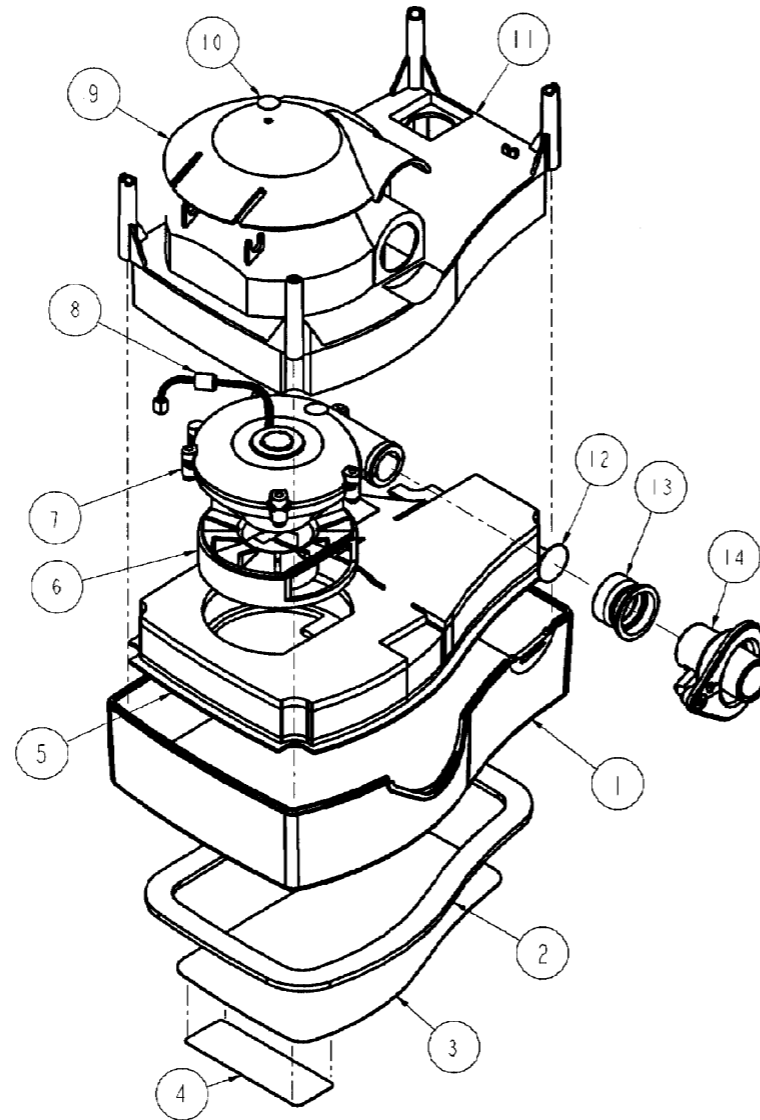

Item	Description
33	Assembly, PCB, main board
34	Shield, alarm
35	Battery, coin cell, lithium 3V